

# Load Flow Analysis by Newton Raphson Method

VISHAL V. MEHTRE<sup>1</sup>, UTKARSH RAJ VERMA<sup>2</sup>

<sup>1</sup> Assistant Professor, Department of Electrical Engineering, Bharati Vidyapeeth University, Bharati Vidyapeeth (Deemed to be University), College of Engineering, Pune, Maharashtra, India

<sup>2</sup> Student, Department of Electrical Engineering, Bharati Vidyapeeth University, Bharati Vidyapeeth (Deemed to be University), College of Engineering, Pune, Maharashtra, India

**Abstract-** Load flow solutions are necessary for planning, operation, economic scheduling, exchange of power between utilities, etc. In the power system load flow problems can be solved very effectively by Newton-Raphson method. This method is introduced in 1961, Newton's method is successive approximation procedure based on an initial estimate of unknown and the use of Taylors series expansion. This method gives load flow solutions by using reference standard bus and line data of system. In solution of load flow problem it gives magnitude of voltage at different buses as well as voltage angle, line to line active and reactive power flow. This method has been used to obtain load flow solutions and it is tested on IEEE 30-bus system. But finding solution theoretically takes long time so power flow analysis is done by the use of MATLAB programming

**Indexed Terms-** load flow analysis, 30 bus system, iterations, convergence ,bus admittance matrix, jacobian matrix.

## I. INTRODUCTION

Load flow problem can be solved by various methods viz. Gauss-Seidal, Newton Raphson, Fast Decoupled load flow method. These methods are iterative in nature as the equations formed in the load flow problem are nonlinear algebraic equations. Basically, iterative methods converge slowly and are subjected to ill conditioned situations. Over the past few years, developments have been made in finding digital computer solutions for power system load flows. This involves increasing the reliability and the speed of convergence of the numerical-solution techniques [3]

In routine use, even few failures to give first-time convergence for physically feasible problems can be

uneconomical. Hence, the Newton-Raphson (NR) approach is the most preferred general method. The idea of this method starts with an initial guess which is reasonably close to the true root, then the function is approximated by its tangent line and one computes the x- intercept of this tangent line, which is easily done with elementary algebra. This x-intercept with typically be a better approximation to the function root than the original guess and the method can be iterated. Basically Newton's method was first published in 1685 in A Treatise of Algebra both historical and practical by John Wallis. In 1690 Joseph Raphson published, a simplified description in analysis acqyationum universalis. Raphson again viewed Newton's method purely as an algebraic methods and restricted its use to polynomials but he describes the method in terms of successive approximation instead of the more complicated sequence of polynomials used by newton's method. In this method memory required is minimal and directly proportional to size of problem and also the number of iterations for solution increases with size of problem. But for the large problem, the iterative methods are very effective. This paper describes NR method to solve the load flow problem which offer number of advantages than other load flow solution methods [6].

From the load flow studies, the voltage magnitudes and angles at each bus in the steady state can be obtained. Once the bus voltage magnitudes and their angles are computed using the load flow, the real and reactive power flow through each line can be computed. Also the losses in a particular line can be computed. The over and under load conditions from the load flow solution can also be determined [1].

## II. LOAD FLOW ANALYSIS

N-R Load Flow in Distribution Systems-The distribution systems usually fall into the category of ill conditioned power systems for generic Newton-Raphson like methods with its special features, such as Radial or Weakly Meshed Topologies-Most of the distribution systems are radial or weakly meshed types. The increase in requirements for reliability and outgoing distribution generation has made the structure of distribution systems more complex. Therefore, the power flow analysis in such distributions Systems has become more difficult.

High R/X Ratio of The Distribution Lines-Transmission networks are composed mainly of overhead lines thus; the ratio is usually lower than 0.5. In distribution networks where both overhead lines and cables are used, the R/X ratio is high ranging from 0.5 to as high as 7, where high ratio values are typically for low voltage networks.

Unbalanced Operation-Three-phase unbalanced orientation greatly increases the complexity of the network model, since phase quantities have to be considered including mutual couplings.

Loading Conditions-Most of the load flow methods were developed assuming a static load model. But a practical load model is required for getting reliable results.

Dispersed Generation-Distributed generation is being increasingly used to meet the fast load increase in the deregulation era. The utilities have to analysis the operating conditions of the radial-type systems with distributed sources.

Non-Linear Load Models-Widespread use of non-linear loads such as, rectifiers in distribution system distorts the current drawn from the source. Usually the commercial SCADA/DMS systems treat these distribution systems as independent parts, i.e., HVAC (high voltage a.c.) loop and MVAC (medium voltage a.c.) or LVAC (low voltage a.c.) radial systems. Such rough equivalence will cause inaccuracies in the power flow solutions.

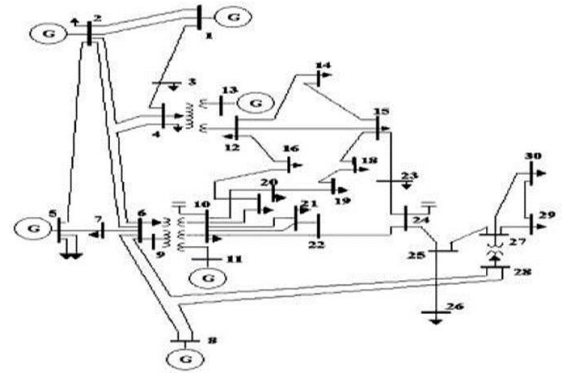

Fig -1: IEEE 30 bus system

The IEEE 30-Bus Test System data is used as input in the program to generate the load flow solution as shown in N-R program .test is carried out on 30 bus 6 unit system.30 bus 6 unit system is shown in fig (b)For load flow analysis by N-R method different problems in the system are taken and solution obtain by NR method.

## III. NEWTON-RAPHSON METHOD

This method was named after Isaac Newton and Joseph Raphson. The origin and formulation of Newton Raphson method was dated back to late 1960s. It is an iterative method which approximates a set of non-linear simultaneous equations to a set of linear simultaneous equations using Taylor's series expansion and the terms are limited to the first approximation.

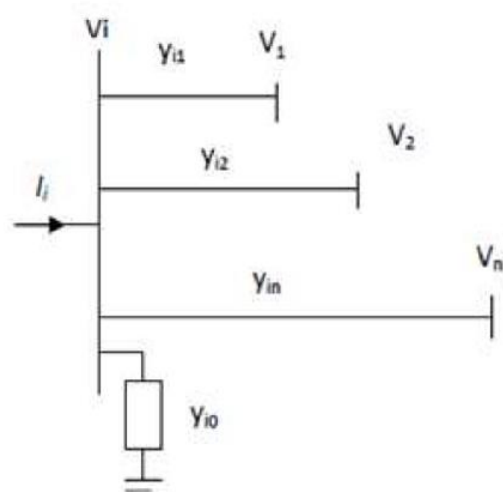

Fig -2: A typical bus of the power system

3.1. Load Flow Algorithm

The Newton Raphson Procedure as Follow-

Step-1: Choose the initial values of the voltage magnitudes  $|V|^{(0)}$  of all  $n_p$  load buses and  $n - 1$  angles  $\delta(0)$  of the voltages of all the buses except the slack bus.

Step-2: Use the estimated  $|V|^{(0)}$  and  $\delta(0)$  to calculate a total  $n - 1$  number of injected real power  $P_{calc}(0)$  and equal number of real power mismatch  $\Delta P^{(0)}$ .

Step-3: Use the estimated  $|V|^{(0)}$  and  $\delta(0)$  to calculate a total  $n_p$  number of injected reactive power  $Q_{calc}(0)$  and equal number of reactive power mismatch  $\Delta Q^{(0)}$ .

Step-4: Use the estimated  $|V|^{(0)}$  and  $\delta(0)$  to formulate the Jacobin matrix  $J(0)$ . Step-4: Solve (4.30) for  $\delta(0)$  and  $\Delta$

$$|V|^{(1)} \div |V|^{(0)}$$

Step-5: Obtain the updates from

$$\delta^{(1)} = \delta^{(0)} + \Delta \delta^{(0)} \tag{A}$$

$$|V|^{(1)} = |V|^{(0)} \left[ 1 + \frac{\Delta |V|^{(0)}}{|V|^{(0)}} \right] \tag{B}$$

Step-6: Check if all the mismatches are below a small number. Terminate the process if yes. Otherwise go back to step-1 to start the next iteration with the updates given by (A) and (B).

3.2 Cases

Examples

Case1: The load at10 bus is increased by 90%from the base case values from (5.8+j2.0)MVA to (11.02+3.8j)MVA .Due to the Breakage of the line 1-2 it results in the overloading on two lines 1-3 and 3-4 respectively .Determine active and reactive power flows through line 1-3 and 3-4.also line losses only from 1-3 and 3-4.

Case1 Result: Power flow solution by Newton Raphson ,No of iterations :10

Table-1: Power flow solution by Newton Raphson for case1

From Line	To Line	Mw load bus	Mvar load bus	Mva gen. bus	Mw gen.bus	Mvar
1	3	316.891	84.088	327.858	43.398	173.760

3	4	271.093	-90.871	285.918	12.449	35.011
---	---	---------	---------	---------	--------	--------

Case2: The load at20 bus is increased by 40%from the base case values from (2.2+j0.7)MVA to (3.08+0.98j)MVA .Due to the Breakage of the line 1-2 it results in the overloading on two lines 1-3 and 3-4 respectively .Determine active and reactive power flows through line 1-3 and 3-4.also line losses only from 1-3 and 3-4.

Case2 Result: Power flow solution by Newton Raphson ,No of iterations :10

Table-2: Power flow solution by Newton Raphson for case2

Fro m Lin e	To Lin e	Mw load bus	Mvar load bus	Mva gen. bus	Mw gen. bus	Mvar
1	3	309.052	78.622	318.895	41.057	164.146
3	4	265.595	-86.725	279.396	11.772	33.060

CONCLUSION

This paper considers two different cases for two buses in which increased the load bus data and find the solutions by using Newton Raphson method. After increasing the value of load bus data, the results which obtained includes the various parameters likes active power flowing through each line, reactive power flowing through each line, voltage magnitude at each bus, reactive power injected in the system and total line losses has been obtain. application of Newton Raphson method for load flow analysis gives the advantages as it is faster, more accurate, and more reliable than any other known method for any size or any kind of problem. Because of computer memory restrictions, present experience has been limited to the polar formulation of this method; an alternative rectangular formulation, having identical convergence properties, might prove more advantageous when computer memory is not critical. but it does not perform satisfactorily for systems with high R/X ratios.

REFERENCES

- [1] Saadat H., Power System Analysis, Tata McGraw-Hill, New Delhi, 1999, 2002
- [2] Wadhwa C.L., Electrical Power Systems, New Age, New Delhi, 1983, 6th edition.
- [3] A. F. Glimn and G. W. Stagg, "Automatic calculation of loadflows," Trans. AIEE (Power Apparatus and Systems), vol.76, p. 817, October 1957.
- [4] B. Venkatesh, A. Dukpa, and L. Chang, "An accurate voltage solution method for radial distribution systems", Can. J. Elect. Comput. Eng., Vol. 34, No. 1/2, 2009
- [5] Tinney W. F., and Hart C. E, 'Power flow solution by Newton's method', IEEE Trans., 1967, Pas-86, pp. 1449-1456
- [6] B. Stott, "Effective starting process for Newton-Raphson load flows" PROC. IEE, Vol. 118, No. 8, August 1971, pp. 983-987.
- [7] Jianwei Liu, M. M. A. Salama and R. R. Mansour, "An efficient power flow algorithm for distribution systems with polynomial load", International Journal of Electrical Engineering Education, 39/4, 2002, pp. 371-385.
- [8] P.R. Bijwe and S.M. Kelapure, "Nondivergent Fast Power Flow Methods", IEEE Trans. on Power Systems, Vol. 18, No. 2, May 2003, 633-638.
- [9] W. H. Kersting, "A method to design and operation of a distribution system", IEEE Trans. Power Apparatus and Systems, PAS-103, pp. 1945-1952, 1984.
- [10] Biswarup Das, "Consideration of Input Parameter Uncertainties in Load Flow Solution of Three-Phase Unbalanced Radial Distribution System", IEEE Transactions on Power Systems, Vol. 21, No. 3, August 2006.
- [11] H. Shateri and S. Jamali, "Load Flow Method for Distribution Networks with Multiple Source Nodes", IEEE Electrical Power & Energy Conference, 3/08, 2008.