

# Design Modification in NRV & Hose Fitting Machine

SHARAD GAIKWAD<sup>1</sup>, SHUBHAM CHAVAN<sup>2</sup>, OMKAR NAGALGAVE<sup>3</sup>, VIJAY KENJALE<sup>4</sup>,  
HRISHIKESH GADEKAR<sup>5</sup>  
*1, 2, 3, 4, 5 ISB&M SOT, Pune*

*Abstract- There is tremendous growth in automobile and automation in last few years so to increase the productivity and performance of automations. we have to make unique research and development works. Its implementation in one organisation can lead to another one elsewhere .the ability to modify NRV and hose fitting assembly to increase the work flow is yet another effective point.in this project we are making a design modification in the assembly design of NRV and hose fitting this is one of the project from NAYAN ELECTRONICS who included us in their company project and sponsored our ideas. By using the various techniques and data base along with the old methods there are certain issues like flexibility and current systems being in capable properly mapping the relationship. It could result in the origin of multiple query statements. There by decreasing the queries and stop wasting industrial material adding our new modified die design.*

*Hence the focus of the system is to facilitate use us to easily transfers the dies. In this project we are properly mapping of the system requirement and working on it.*

## I. INTRODUCTION

In this work the old fixed dies which was fixed they can be replaced by new adjustable dies. we perform various experiments on the basis of testing of different types of sensors, materials and we got various results Firstly we have tested the material is plastic, but it has lower strength than the steel and cast iron. The strength of both cast iron and steel is also controversial, as some think steel is stronger than cast iron and others think that iron and steel is same thing, but the truth is that cast iron has a more compressive strength, and steel is more tensile. Steel is an alloy or iron, and cast iron is a hard grey metal.so for increasing the life of the machine we are selected cast iron as a raw material for making machine. Cast iron is much harder and brittle than the steel.

It has more compression strength than steel so where the toughness is not required hence cast iron is suitable material to be used because of its high hardness value. You can see grey cast iron used in the machine belts due to its great ability to absorb vibrations The hardness of the strongest grades is double as that of the weakest grades all grey cast iron have high compressive strength three to four times of their tensile strength while all grey cast iron contain free carbon (Graphite) In flake form, they also contain combined carbon (Iron carbon) in almost every case. We can achieve comfortable assemblies for NRV AND HOSE by using this type of machine because of changeable dies we can reduce the effective assembly cost.

We can save lot of money which we are spending for changing directly the new machine for new sizes of NRV AND HOSE by achieving the new technique we can increase the productivity and quantity of our production.

## II. MATH

- 1) Dimensions of upper block  
Length of upper block = 69.91 mm  
Width of upper block = 55.91 mm  
Height of upper block = 69.91 mm
- 2) Dimensions of lower block  
Length of lower block = 69.91 mm  
Width of lower block = 55.91 mm  
Height of lower block = 24.09 mm
- 3) Volume of upper block  
 $= l*b*h = 69.91*55.91*69.91=273.254*10^3 \text{ m}^3$
- 4) Volume of lower block  
 $= l*b*h = 69.91*55.91*24.09=94.159*10^3 \text{ m}^3$
- 5) Diameter of hose  
 $= Dh = 9 \text{ mm}$
- 6) Diameter of Large screw holes  
 $= D = 9 \text{ mm}$
- 7) Diameter of small screw holes  
 $= d = 5 \text{ mm}$

- 8) Max operating pressure = 10 bar
- 9) Current Operating Pressure = 5 bar.

III. UNITS

Bar  
MM  
M<sup>3</sup>

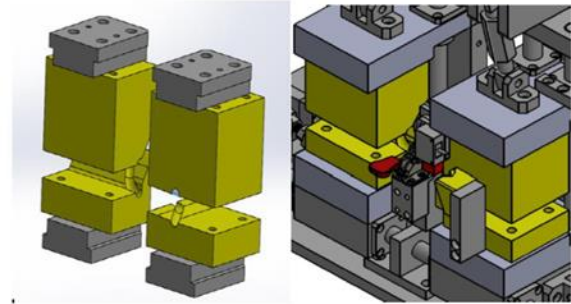

New Design

Old Design

Fig No. 1 Design Implementation in Part

IV. HELPFUL HINTS

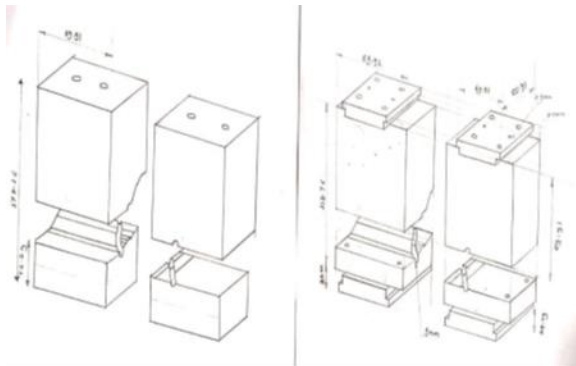
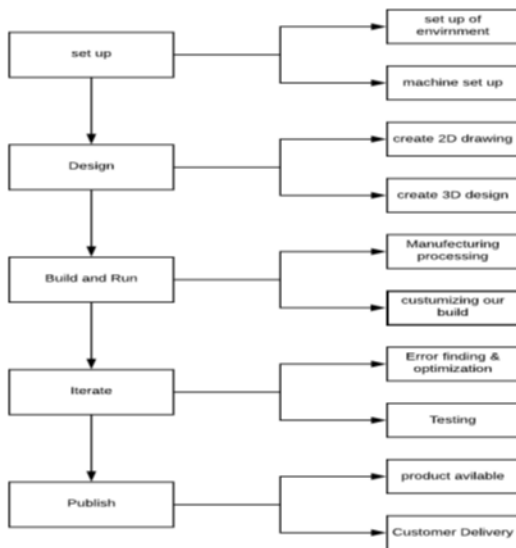

CONCLUSION

After several design modifications we achieved an important chance which makes easy process of interchange ability of die. Now in future we are looking for other changes in machine design which can cut the cost as well as improve the performance characteristics of machine. Our aim is to achieve our best success by doing our best work. NAYAN ELECTRONICS is giving us a training about sensors used in that machine in next 1 month from 20-12-19 to 20-12-19. While getting the sensors training, we will also involve in the designing and modifying the assembly machine for nrv and hose fitting as well as will be further involved in manufacturing process of the machine. After passing all the processes and testing we are ready to use that machine for nrv and hose fitting of various four wheelers. Coolant hoses include the upper and lower radiator hoses plus heater hoses. Some cars include a bypass hose. Hoses provide a flexible connection for coolant flow between the engine, radiator, engine and heating block. After all the design, manufacturing & Testing procedures we will give that machine to the customers in automation industry. By doing changes in old designs we want to save money as well as we want to increase the flexibility, performance of the machine.

APPENDIX

Hoses that are lying on ground are installed in tricky locations are offend users find it difficult to identify to tell which hose is which as the outer wall is often black in color this can be dangerous situation to avoided this

situation hoses should be mark clearly according to standards

#### REFERENCES

- [1] Hyunjin Choi and Kyoungchul Kong, "A Soft Three-Axis Force Sensor Based on Radially Symmetric Pneumatic Chambers", IEEE SENSORS JOURNAL, VOL. 19, Page NO. 13, JULY 1, 2019.
- [2] B. Ellger, D. Kiski , E. Diem a, I. van den Heuvel , H. Freise , H. Van Aken ,F. Hinder , A.W. Friedrich, "Non-return valves do not prevent backflow and bacterial contamination of intravenous infusions", Journal of Hospital Infection 78,Page NO.31-35, 11 March 2011.
- [3] Lei Ge, Zhixin Dong, Weinan Huang, Long Quan, Jing Yang, Wenyong Li, "Research on the Performance of Hydraulic Excavator with Pump and Valve Combined Separate Meter IN and Meter Out Circuits", International Conference on Fluid Power and Mechatronics IEEE, Page NO.5-7, August 2015.
- [4] Wei Guo, Weimin Cui, Tuo Zhang, Tianxiang Yu, "The Research on Failure Issues for Hydraulic System", School of Aeronautics North-western Polytechnic University, China IEEE, Page NO.817-819, December 8,2012.
- [5] B. Jeeva, J.R. Suresh Babu and M. Chitra, "Study of Inter-Integrated Circuit Colour Sensor with Microcontroller", NIET & Anna University IEEE, Page NO.1-5, December 4, 2012.
- [6] Jiangni Lei, Fangyi Wan, Weimin Cui, Wenheng Li, "Testability Modelling of Hydraulic System Based on Multi - Signal Flow Model", School of Aeronautic North-western Polytechnic University IEEE, Page NO.361-366, Sep.2017.
- [7] Yanbing LI, Meng YUAN and Jiyong XU, "A Pressure Sensor Study and Research", Suqian, Jiangsu Province IEEE, Page NO.255-258, November 6, 2011.
- [8] Haojian Lu and Junyao Gao, Lin Xie, Xin Li, Zhe Xu, Yi Lio, Jingchao Zhao, Haoxiang Cao, Fangzhou Zhao and Xuanyang Shi, "Single Hydraulic Actuator Actively-Compliant Research Based on the Hydraulic Quadruped Robot", International Conference on Information and Automation Lijiang IEEE, Page NO.1331-1336, August 2015.
- [9] Xing Luo, Jihong Wang, Hao Sun, James W. Derby, and Stephen the Scroll Expander Technology", ASME Transactions on Mechatronics IEEE, VOL. 18, page NO. 5, October 2013.
- [10] Shunmugham R. Pandian, Fumiaki Takemura, Yasuhiro Hayakawa and Sadao Kawamura, "Pressure Observer-Controller Design for Pneumatic Cylinder Actuators", ASME Transactions on Mechatronics IEEE, VOL. 7, Page NO. 4, December 2002.
- [11] Pha N. Pham, Kazuhisa Ito, "A Simulation of Digital Load Sensing System for Water Hydraulics", Department of Machinery and Control Systems Shibaura Institute of Technology IEEE, Page No.1-8, October 2015.
- [12] Julie Mitchell, "Research into A Sensor-Based Diagnostic Maintenance Expert System for the Hydraulics of a Continuous Mining Machine", Electrical Engineer U.S. Bureau of Mines Pittsburgh, Page NO.1192-1193, May 1991.
- [13] Pavel Ripka, Andrey Chirtsov, Mehran Mirzaei, and Jan Vyhnaneek, "Inductance position sensor for pneumatic cylinder", Faculty of Electrical Engineering, Czech Technical University, Page NO. 1-7, 12 October 2017.
- [14] Sy Najib Sy Salim, Aliza Che Amran, M.F. Rahmat, N.H.Sunar, A. A. M. Faudzi, Z. H. Ismail and Shamsul Anuar Shamsudin, "A Study on Tracking Performance of The Pneumatic System with Enhanced NPID Controller", Department of Control, Instrumentation and Automation, Faculty of Electrical Engineering, University Technical Malaysia Melaka IEEE, Page NO.1-7, May 2015.
- [15] Martin Sirovy, David Vosmik, "Sensor less Pump Control Strategy for Hydraulic Systems of Heating Applications Driven by Robust Encoder less PMSM Drive", University of West Bohemia / Faculty of Electrical Engineering IEEE, Page NO.1-10, Dec.2010.
- [16] Yang Song, Leisheng Huang, Tao Wang, Wei Fan, "Research on the Friction of the Pneumatic Servo System", International Conference on

- Fluid Power and Mechatronics IEEE, Page no.27-30, Feb.2015.
- [17] Tian Junying and Han Jianhai, "Research on Extension Element Model in Hydraulic System", International Conference on Mechatronics and Automation IEEE, Page NO.9-12, May 2009. J. Mangan, "Study of a New Strategy for Pneumatic Actuator System Energy Efficiency Improvement via the Scroll Expander Technology", ASME Transactions on Mechatronics IEEE, VOL. 18, page NO. 5, October 2013.
- [18] Shunmugham R. Pandian, Fumiaki Takemura, Yasuhiro Hayakawa and Sadao Kawamura, "Pressure Observer-Controller Design for Pneumatic Cylinder Actuators", ASME Transactions on Mechatronics IEEE, VOL. 7, Page NO. 4, December 2002.
- [19] Pha N. Pham, Kazuhisa Ito, "A Simulation of Digital Load Sensing System for Water Hydraulics", Department of Machinery and Control Systems Shibaura Institute of Technology IEEE, Page No.1-8, October 2015.
- [20] Julie Mitchell, "Research into A Sensor-Based Diagnostic Maintenance Expert System for the Hydraulics of A Continuous Mining Machine", Electrical Engineer U.S. Bureau of Mines Pittsburgh, Page NO.1192-1193, May 1991.
- [21] Pavel Ripka , Andrey Chirtsov, Mehran Mirzaei, and Jan Vyhnanek, "Inductance position sensor for pneumatic cylinder", Faculty of Electrical Engineering, Czech Technical University, Page NO. 1-7, 12 October 2017.
- [22] Sy Najib Sy Salim, Aliza Che Amran, M.F. Rahmat, N.H.Sunar, A. A. M. Faudzi, Z. H. Ismail and Shamsul Anuar Shamsudin, "A Study on Tracking Performance of The Pneumatic System with Enhanced NPID Controller", Department of Control, Instrumentation and Automation, Faculty of Electrical Engineering, University Technical Malaysia Melaka IEEE, Page NO.1-7, May 2015.
- [23] Martin Sirovy, David Vosmik, "Sensor less Pump Control Strategy for Hydraulic Systems of Heating Applications Driven by Robust Encoder less PMSM Drive", University of West Bohemia / Faculty of Electrical Engineering IEEE, Page NO.1-10, Dec.2010.
- [24] Yang Song, Leisheng Huang, Tao Wang, Wei Fan, "Research on the Friction of the Pneumatic Servo System", International Conference on Fluid Power and Mechatronics IEEE, Page no.27-30, Feb.2015.
- [25] Tian Junying and Han Jianhai, "Research on Extension Element Model in Hydraulic System", International Conference on Mechatronics and Automation IEEE, Page NO.9-12, May 2009.

#### ACKNOWLEDGMENT

It gives me great pleasure to present this report, a written testimony of the most fruitful Project we have undergone. Firstly, we would like to thank to Prof Hrishikesh Gadekar for giving me an opportunity to work on this project.

We whole-heartedly thank to my college guide Prof Hrishikesh Gadekar & also thank to our project Co-ordinator Prof Gunwant Ghatole who has been a source of encouragement & motivation for me during our project. We are delicately to them for all their help and support and also special thanks to Mr. Arun Jangam sir from NAYAN ELECTRONICS for giving a chance to work with his industry.

Lastly, we want to thank whole 'ISB&M SCHOOL OF TECHNOLOGY CAMPUS' for their needed cooperation.

During our project work & for enormous qualities & knowledge that we have gained during project training Period which will definitely help us in developing good career.