

Assessment among Single and Three Phase 28-Echelon Cascaded Multilevel Inverter with Three H-Bridge Inverter Modules

RAM SWAROOP¹, SUMAN SAINI²

^{1,2} Dept. of Electrical Engineering, Shekhawati Institute of Engineering and Technology, Sikar

Abstract -- The function of this work is to minimize total harmonics distortion and number of switch and improve level in output voltage waveform. In conventional method, needed five H-bridge units to used 11-echelon inverter but in this proposed method for a 28-echelon cascaded H-bridge multilevel inverter required only three H-bridge unit per phase. By using this proposed idea it reduces the total harmonics distortion through the appending of echelons. In this work both single phase and three phase total harmonics distortion and number of switch has reduced. Simulation result is providing for 14-echelon and 28-echelon cascaded H-bridge multilevel inverter to validate the accuracy of computational result. Single phase and three phase simulation result was 14-echelon cascaded H-bridge multilevel inverter the total harmonics distortion level is 16.12%. The simulation result gives the total harmonic distortion level for single phase and three phase 28-echelon cascaded H-bridge multilevel inverter that is 12.61%. Therefore the total harmonic distortion in 28-echelon inverter is less by 3.51% with respect to 14-echelon inverter. Comparison of result with active harmonics reduction techniques indicates that the total harmonics distortion and switching frequency of output voltage reduced dramatically.

Indexed Terms: Matlab 12b, Multilevel Inverter, AC and DC Voltage, Cascaded Connection

I. INTRODUCTION

One multilevel inverter topology inclusive single phase cascaded H-bridges with separate DC voltage sources from the transformer secondary. This importance makes renewable energy sources such as fuel cells or photovoltaic a temperament (natural) preference for the separate DC voltage sources required for the cascade multilevel inverter. Figure shows a single-phase block diagram of an m-level cascade inverter. Each isolated DC voltage source is connected to a single phase fully H-bridge inverter. Each H-bridge inverter level can produce three different voltage outputs, that are +Vdc, 0, and -Vdc, by connecting the DC voltage source to the AC output by various combinations of the four switches

S1, S2, S3 and S4. One of the main advantages of the cascaded multilevel inverter is that the series connection of H-bridges makes for modularized layout and packaging. This will enable the manufacturing development to be done more quickly and inexpensively. Also, redundant voltages level can be presented in a consumption plan so that the multilevel inverter can stable operate even with the shortage of one level.

II. IDENTIFY, RESEARCH AND COLLECT IDEA

This enables the 3 multilevel inverter to continue to function even when there is a problem with one of the DC sources or with one of the power electronics devices that make up the H-bridge. The cascaded multilevel inverter is constructed depends on the number of echelons. For the production m-level inverters, totally it needs (m-1) capacitors and 2 (m-1) switches. And also it requires 2(m-1)(m-2) diodes to clamp the voltage at difference voltage level. Gate signal is produced by using the comparator. The ramp signal is compared with DC voltage. By adjusting the DC magnitude the pulse width is controlled. Here the bottom switch conducts for large time than the upper switch.

A cascaded H-bridge multilevel inverter consists of a series of single phase fully H-bridge inverter units. The main aim of this cascaded multilevel inverter is to synthesize a desired voltage from several isolated DC voltage sources from transformer secondary, which may be obtained from batteries, fuel cells, or solar cells. Figure shows the basic block diagram of a single phase cascaded multilevel inverter with isolated DC voltage sources. Each isolated DC voltage source connected to an H bridge inverter unit.

The AC terminal voltages of various level inverters are connected in series. The cascaded multilevel inverter does not need any voltage balancing capacitors and clamping diodes, unlike the flying capacitors and diode clamp inverter.

III. WRITE DOWN YOUR STUDIES AND FINDINGS

Among three types of methodology, the proposed methodology is cascaded H-bridge multilevel inverter method. In this method, the diode clamps the voltage across the switch to one level, and all diodes are selected as same type i.e. same voltage withstanding capacity. The diode provides the forward path and feedback path in case of the current.

Therefore the voltage of separate DC sources for each H-bridge units is considered in the form of $V_{dc1} < V_{dc2} < V_{dc3}$. The switching system is controlled by firing unit, each H-bridge having separate firing unit to control the switching system in the cascaded H-bridge multilevel inverter.

$$V_{dc1} : V_{dc2} : V_{dc3} = V_{dc} : 3V_{dc} : 9V_{dc}$$

- Mode-I ($0 < \omega t < \omega t_1$):

The output voltage in this mode is zero. Either the switches S1 and S3 are on and S2 and S4 are off or S2 and S4 are on and S1 and S3 are off conditions in all H-bridge units. In this condition the separate DC source which connected to each H-bridge has not close with the load and therefore the output voltage is zero.

- Mode-II ($\omega t_1 < \omega t < \omega t_2$):

In this mode, the switches S1 and S4 are on and S2 and S3 are off in first H-bridge unit, switches either S1 or S3 are on and S2 and S4 are off or S2 and S4 are on and S1 and S3 are off in the second and third H-bridge units. In this condition only first H-bridge unit DC source is connect to the load, so the output voltage in this mode is V_{dc} .

IV. SIMULATION RESULTS

The simulation results of single phase and three phase for the developed 14-echelon cascaded multilevel inverter proposed to minimize the total harmonic distortion with using of reduced number of switches and increase level in the output voltage waveform. There are connected three H-bridge inverters in the cascaded form and each H-bridge inverter is supplied by separate DC voltage source. The ratio of the separate DC voltage sources (V_{dc1} , V_{dc2} and V_{dc3}) that used in single phase and three phase 14-echelon cascaded H-bridge multilevel inverter, as given by-

$$V_{dc1} : V_{dc2} : V_{dc3} = 1 V_{dc} : 2 V_{dc} : 3 V_{dc}$$

Therefore the voltage of separate DC sources for each H-bridge units is considered in the form of $V_{dc1} < V_{dc2} < V_{dc3}$. The switching system is controlled by firing unit, each H-bridge having separate firing unit to control the switching system in the cascaded H-bridge multilevel inverter. Simulation is done the simulation result shown in single phase and three phases cascaded multilevel inverters and calculate the total harmonic distortion by using the FFT analysis.

Simulation Model for Single Phase

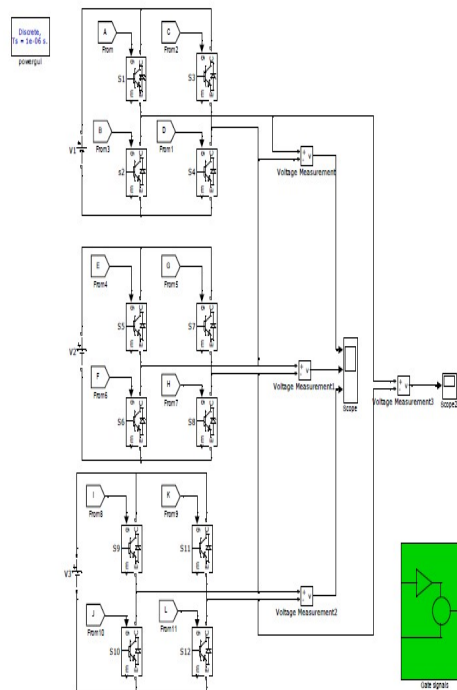

Parameters	Value
Phase	Single
Frequency	50Hz
V _{dc1}	9V
V _{dc2}	18V
V _{dc3}	27V
Load	No Load

V. RESULT

The value of separate DC voltage sources is given in the Table. The phase difference of output voltage waveform is 120o between the each two phases and the output voltage (Vo) of the each phase of the H-bridge cascaded multilevel inverter is given by

$$V_o = V_{o1} + V_{o2} + V_{o3}$$

Sr. No.	Order of Harmonics	Frequency in Hz	Harmonics in %
1	3 rd	150	14.64%
2	5 th	250	2.35%
3	7 th	350	3.14%
4	9 th	450	0.16%
5	11 th	550	1.44%
6	13 th	650	0.25%
7	15 th	750	0.81%
8	17 th	850	0.38%
9	19 th	950	0.49%
Total			16.12%

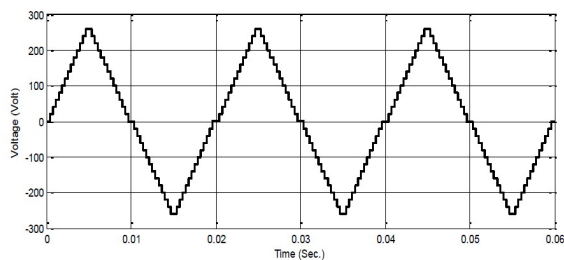

VI. CONCLUSION

In this work both single phase and three phase total harmonics distortion and number of switch has reduced. Simulation result is providing for 14-echelon and 28-echelon cascaded H-bridge multilevel inverter to validate the accuracy of computational result. Single phase and three phase simulation result

was 14-echelon cascaded H-bridge multilevel inverter the total harmonics distortion level is 16.12%. The simulation result gives the total harmonic distortion level for single phase and three phase 28-echelon cascaded H-bridge multilevel inverter that is 12.61%. Therefore the total harmonic distortion in 28-echelon inverter is less by 3.51% with respect to 14-echelon inverter. Comparison of result with active harmonics reduction techniques indicates that the total harmonics distortion and switching frequency of output voltage reduced dramatically.

REFERENCES

- [1] G. Carrara, S. Gardella, M. Marchesoni, R. Salutari, and G. Sciutto, "A New Multilevel Pulse Width Modulation Method: A Theoretical Analysis", IEEE Transaction Power Electronics, Volume 7, no. 3, pp. 497-505, Jul. 1992
- [2] A. Nabae and H. Akagi, "A New Neutral-Point Clamped Pulse Width Modulation Inverter", IEEE Transactions on Industrial Electronics, Volume IA-17, no. 5, pp. 518-523, Sep. 1981
- [3] J. Pou, R. Pindado, and D. Boroyevich, "Voltage-Balance Limits in Four level Diode-Clamped Converters With Passive Front End", IEEE Transactions on Industrial Electronics, Volume 52, no. 1, pp. 190-196, Feb. 2005
- [4] S. Alepuz, S. Busquets-Monge, J. Bordonau, J. Gago, D. Gonzalez, and J. Balcells, "Interfacing Renewable Energy Sources to the Utility Grid Using A Three-Level Inverter", IEEE Transaction Industrial Electronics, Volume 53, no. 5, pp. 1504-1511, Oct. 2006
- [5] A. Nabae and H. Akagi, "A New Neutral-Point Clamped Pulse Width Modulation Inverter", IEEE Transaction Industrial Applications, Volume IA-17, no. 5, pp. 518-523, Sep. 1981